



**MPF50S Series Portable
Filtration System
Operating, Service & Parts Manual**



Frymaster, a member of the Commercial Food Equipment Service Association, recommends using CFESA Certified Technicians.

24-Hour Service Hotline 1-800-551-8633

**MAR 2008
* 8196301 ***

Please read all sections of this manual and retain for future reference.

Installation, maintenance, and repairs should be performed by your Frymaster Dean Factory Authorized Service Agency.

 **WARNING**

Safe and satisfactory operation of your equipment depends on its proper installation. Installation **MUST** conform to local codes, or in the absence of local codes, with the latest edition of the National Electric Code, N.F.P.A. 70.

 **WARNING**

ELECTRICAL GROUNDING INSTRUCTIONS

This filter is equipped with a three-prong, grounded plug for your protection against shock hazard and should be plugged directly into a properly grounded, three-hole receptacle. Do not cut off, remove or otherwise bypass the grounding prong on this plug.

If it is necessary to use an extension cord, it **MUST** be a three-conductor, grounded cord of 16 gauge or greater.

 **DANGER**

Do not filter more than one fry tank at a time.

Hot fluid – Do not fill above a point 1-½ inches below the OIL CONTAINER RIM.

 **WARNING**

This filter unit is not suitable for outdoor use. When operating this unit, it **MUST** be placed on a horizontal surface.

 **WARNING**

This filter unit is not suitable for installation in an area where a water jet can be used, and this appliance **MUST NOT** be cleaned with a water jet.

NOTICE:

If this filter unit is cleaned with water, disconnect the unit from power source before cleaning and thoroughly dry the filter unit before reconnecting to electrical power source.

 **DANGER**

The crumb tray (if equipped) in portable filter systems must be emptied into a fireproof container at the end of frying operations each day. Some food particles can spontaneously combust if left soaking in certain shortening material.

NOTICE:

Drawings and photos used in this manual are intended to illustrate operational, cleaning and technical procedures and may not conform to on-site management operational procedures.

NOTICE

IF, DURING THE WARRANTY PERIOD, THE CUSTOMER USES A PART FOR THIS ENODIS EQUIPMENT OTHER THAN AN UNMODIFIED NEW OR RECYCLED PART PURCHASED DIRECTLY FROM FRYMASTER DEAN, OR ANY OF ITS AUTHORIZED SERVICE CENTERS, AND/OR THE PART BEING USED IS MODIFIED FROM ITS ORIGINAL CONFIGURATION, THIS WARRANTY WILL BE VOID. FURTHER, FRYMASTER DEAN AND ITS AFFILIATES WILL NOT BE LIABLE FOR ANY CLAIMS, DAMAGES OR EXPENSES INCURRED BY THE CUSTOMER WHICH ARISE DIRECTLY OR INDIRECTLY, IN WHOLE OR IN PART, DUE TO THE INSTALLATION OF ANY MODIFIED PART AND/OR PART RECEIVED FROM AN UNAUTHORIZED SERVICE CENTER.



**MPF50S Series Portable Filtration Systems
Operation, Service & Parts Manual**

TABLE OF CONTENTS

	Page #
1. INTRODUCTION.....	1-1
2. IMPORTANT INFORMATION.....	2-1
3. FILTER PREPARATION.....	3-1
4. OPERATING/FILTER INSTRUCTIONS.....	4-1
5. CLEANING AND MAINTENANCE.....	5-1
6. TROUBLESHOOTING/SERVICE PROCEDURES.....	6-1
7. PARTS LIST.....	7-1

MPF50S SERIES PORTABLE FILTRATION SYSTEMS

CHAPTER 1: INTRODUCTION

1.1 Parts Ordering

Place parts orders directly with your local Frymaster/Dean Factory Authorized Service Center. A list of FASCs was included with the filter when shipped from the factory. If you do not have access to this list, please contact the Frymaster/Dean service department at 1-800-551-8633 or 1-318-865-1711, or go to Frymaster/Dean's website at: www.frymaster.com.

To help speed your order, the following information is required:

Model Number		Type	
Serial Number			
Optional Features			
Item Part Number		Quantity Needed	

1.2 Service Information

Call the 1-800-551-8633 or (318) 865-1711 Service Hotline number for the location of your nearest Factory Authorized Service Center. Always give the model and serial numbers of your filter unit. Also, identify if your unit is supplied with or without a heater.

To assist you more efficiently, the following information will be needed:

Model Number		Type	
Serial Number			
Optional Features			
Nature of Problem:			

Additional information (i.e. oil temperature at filter time, time of day and other pertinent information) may be helpful in solving your service problem.

MPF50S SERIES PORTABLE FILTRATION SYSTEMS

CHAPTER 1: INTRODUCTION

1.3 After Purchase

In order to improve service, fill out the following chart with the nearest Frymaster Authorized Service Technician and FASC in your area.

Authorized Service Technician/FASC	
Address	
Telephone/Fax	
Filter Model Number	
Filter Serial Number	

1.4 Safety Information

Before attempting to operate your unit, read the instructions in this manual thoroughly.

Throughout this manual, you will find notations enclosed in double-bordered boxes similar to the ones below.

 **CAUTION**

CAUTION boxes contain information about actions or conditions that *may cause or result in a malfunction of your system.*

 **WARNING**

WARNING boxes contain information about actions or conditions that *may cause or result in damage to your system,* and which may cause your system to malfunction.

 **DANGER**

DANGER boxes contain information about actions or conditions that *may cause or result in injury to personnel,* and which may cause damage to your system and/or cause your system to malfunction.

MPF50S SERIES PORTABLE FILTRATION SYSTEMS
CHAPTER 1: INTRODUCTION

1.5 Service Personnel

1.5.1 Definitions

A. Qualified and/or Authorized Operating Personnel

1. Qualified/authorized operating personnel are those who have carefully read the information in this manual and have familiarized themselves with the equipment functions, or have had previous experience with the operation of equipment covered in this manual.

B. Qualified Installation Personnel

1. Qualified installation personnel are individuals, or firms, corporations, or companies that, either in person or through a representative, are engaged in and are responsible for the installation of electrical appliances. Qualified personnel must be experienced in such work, be familiar with all electrical precautions involved, and have complied with all requirements of applicable national and local codes.

C. Qualified Service Personnel

1. Qualified service personnel are those who are familiar with Frymaster/Dean equipment and have been authorized by Frymaster/Dean to perform service on Frymaster/Dean equipment. All authorized service personnel are required to be equipped with a complete set of service parts manuals and stock a minimum amount of parts for Frymaster/Dean equipment. A list of Frymaster/Dean Factory Authorized Service Centers (FASCs) was included with the filter when shipped from the factory. ***Failure to use qualified service personnel will void the Frymaster/Dean warranty on your equipment.***

MPF50S SERIES PORTABLE FILTRATION SYSTEMS

CHAPTER 2: IMPORTANT INFORMATION

2.1 General

MPF50S portable filters can be used with a variety of Frymaster fryers, as well as other manufacturers' equipment. Oil capacity is approximately 50 pounds. Unit specifications are listed below.

Model	Unit Height (inches)	Unit Width (inches)	Unit Length (inches)	Tank Height (inches)	Oil Capacity (pounds)
MPF50S	13- ¹ / ₄	13- ¹ / ₄	30	11- ³ / ₄	50

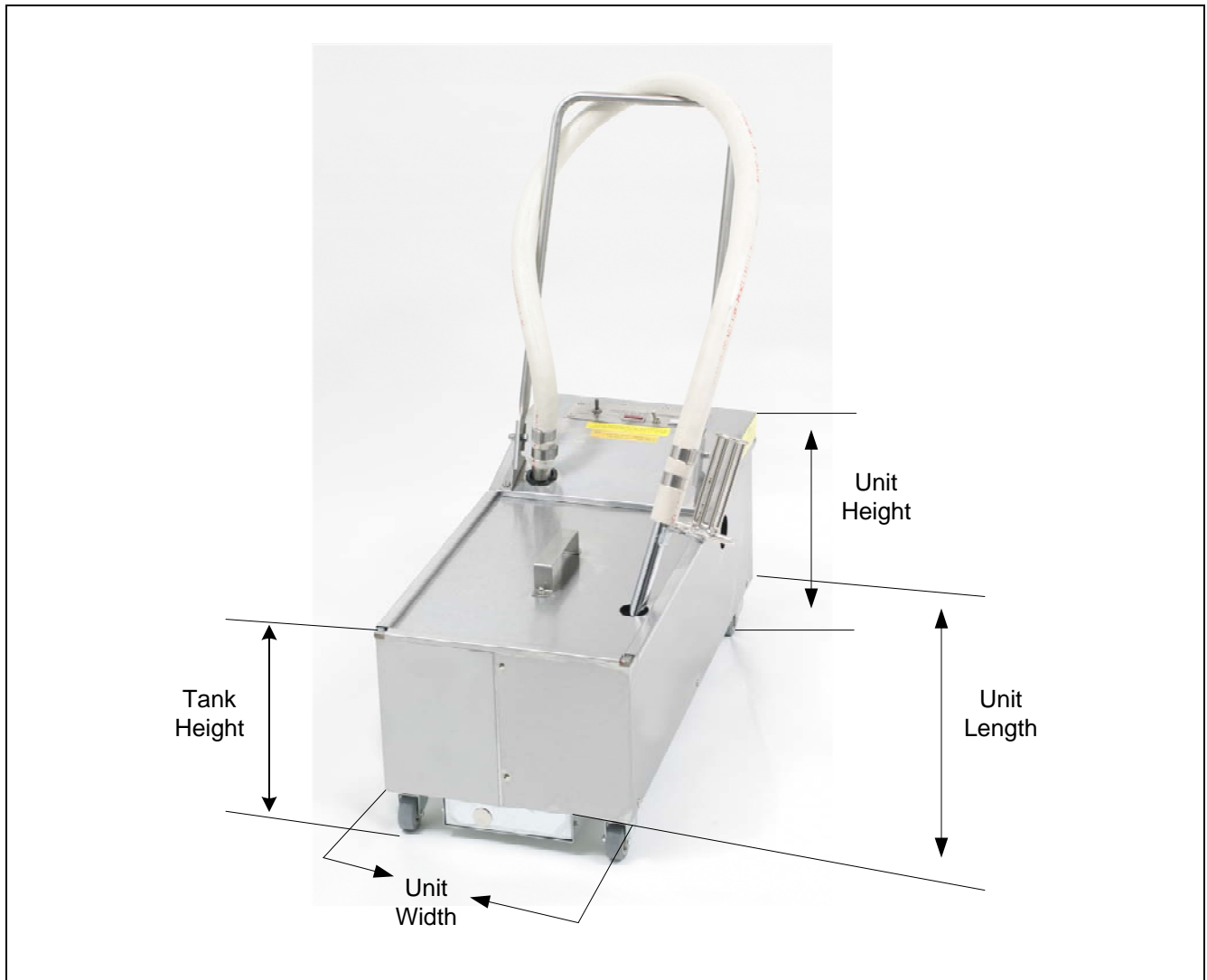

MPF50S Series portable filter dimensions.

MPF50S SERIES PORTABLE FILTRATION SYSTEMS

CHAPTER 2: IMPORTANT INFORMATION

2.1 General (cont.)

Oil or shortening is gravity-drained from the fryer into the filter ("S" Models), or pumped from the frypot into the filter pan, and then filtered through filter paper. Filter powder, which enhances the filtering process, is distributed over the paper prior to filtering.

All units are shipped completely assembled with accessories packed inside the filter pan. All units are adjusted, tested and inspected at the factory before shipment.

WARNING

The on-site supervisor is responsible for ensuring that operators are made aware of the inherent dangers of operating a hot oil filter system, particularly the aspects of oil filtration, and draining/cleaning procedures.

An Off/Return (MPF50S) switch activates/deactivates the filter pump. The filter also has a Heater/Filter switch for use when filtering solid shortening.

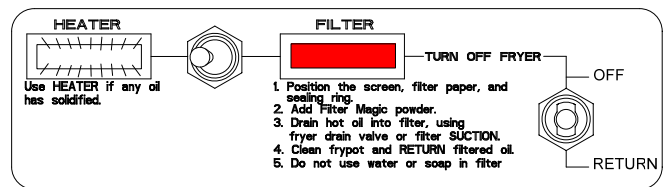

MPF50S switch/light panel

A thermal-overload switch on the pump motor provides protection against overheating.

NOTE: *If the thermal overload is triggered, wait 45 minutes, and then press the reset button to activate the circuit after the failure has been detected and repaired.*



The motor thermal overload switch (arrow) is located on the left side of the filter.

2.2 Rating Plate

Information on the rating plate includes model and serial numbers, as well as electrical requirements. The rating plate is located on the back housing, near the electrical receptacle. Have the rating plate information handy when communicating with the factory about a unit or requesting special parts or information. Without rating plate information, proper identification of the unit cannot be confirmed.

MPF50S SERIES PORTABLE FILTRATION SYSTEMS

CHAPTER 2: IMPORTANT INFORMATION

2.3 Pre-Installation

NOTE: Failure to use qualified service personnel will void the Frymaster warranty.

- A. Standards: Use of this filter unit must be in accordance with all applicable state and local codes.

 **DANGER**

This portable filter is equipped with a three-prong (grounding) plug for protection against electrical shock and must be plugged directly into a properly grounded, three-prong receptacle. DO NOT CUT, REMOVE, OR OTHERWISE BYPASS THE GROUNDING PRONG ON THIS PLUG!

- B. Electrical Connections: Domestic MPF50S filter units require 115V 60 Hz., 15 amp electrical supply. International/CE units require 230V 50 Hz., 7 amp electrical supply. Units are equipped with a grounded male receptacle for use with a 16-3 SJT power cord set. If an extension cord is required, it must be a three-conductor, grounded power cord of at least 16 gauge.

2.4 Unpacking the Filter System

Ensure the container is upright. Unpack the filter carefully and remove all accessories from the carton. Do not discard or misplace parts and/or accessories; they will be needed for filter setup and operation. Any accessories or starter kits included with the unit will be packaged inside the filter tank.

After unpacking, immediately check the equipment for visible signs of shipping damage. If such damage has occurred, contact the carrier and file the appropriate freight claims. Do not contact the factory, as the responsibility of shipping damage is between the carrier and dealer or end-user.

If your equipment arrives damaged:

- a. File claim for damages immediately – Regardless of extent of damage.
- b. Visible loss or damage – Be sure this is noted on the freight bill or express receipt and is signed by the person making the delivery.
- c. Concealed loss or damage – If damage is unnoticed until equipment is unpacked, notify freight company or carrier immediately, and file a concealed damage claim. This should be done within 15 days of date of delivery. Retain the shipping container for inspection.

NOTE: Frymaster does not assume responsibility for damage or loss incurred in transit.

MPF50S SERIES PORTABLE FILTRATION SYSTEMS

CHAPTER 3: FILTER PREPARATION

3.1 Assembling The Filter System

On initial installation and before each use, remove all loose parts from the filter, wash all accessories in hot, soapy water and dry thoroughly. **DO NOT WASH INTERIOR OF FILTER PAN WITH DETERGENT OR WATER!** Wipe debris and residue from the filter pan with a damp cloth or paper towel, then with a dry cloth or paper towel.

⚠ WARNING!

Water, detergent or boil-out solution MUST NOT be allowed into the filter pan or filter system. Irreversible pump damage will result if water is allowed into the system, and the warranty will be voided.

MPF50S Series portable filtration systems use a filter support grid, one sheet of filter paper and a hold-down ring to secure the filter paper in place.

See illustration for proper assembly.

1. Filter Pan Cover
2. Hold-Down Ring
3. Filter Paper (one sheet)
4. Screen/Support Grid
5. Filter Pan

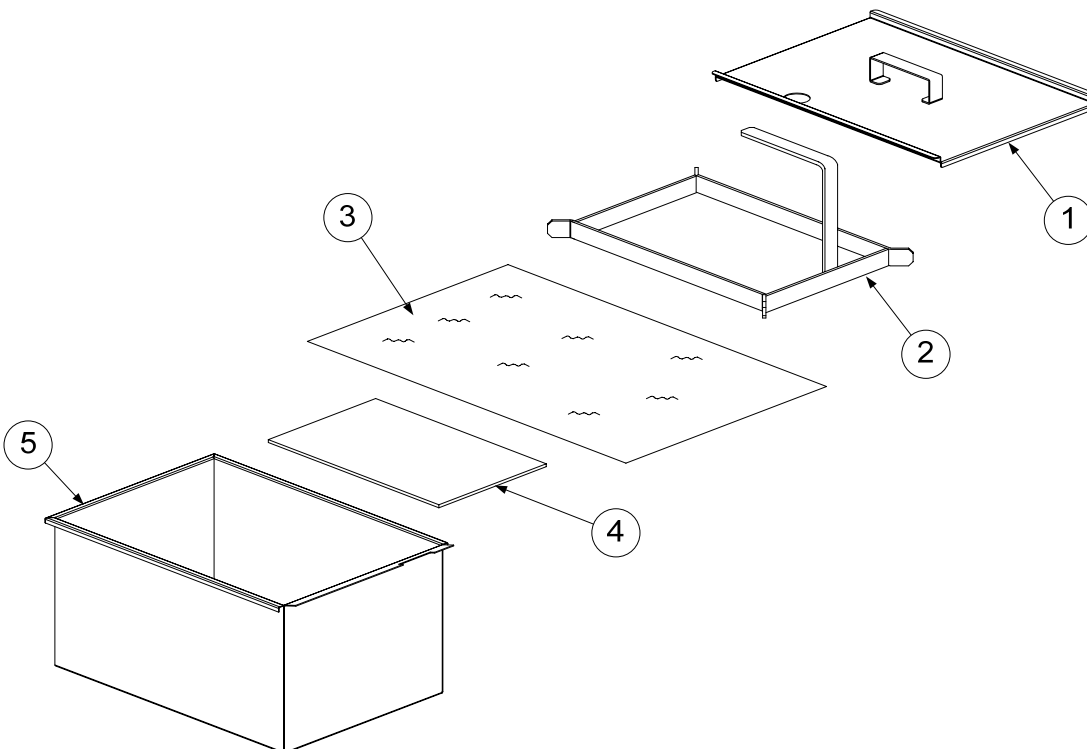

MPF50S SERIES PORTABLE FILTRATION SYSTEMS
CHAPTER 3: FILTER PREPARATION

3.1 Assembling The Filter System

1. Ensure the filter pan is clean and free of all food and breading particles that could prevent the filter paper from sealing against the bottom of the pan.
2. Place the filter paper support screen between the raised dimples in the bottom of the pan.
3. Place one sheet of filter paper on top of the support screen. Ensure the paper evenly covers the filter pan bottom.
4. Position the hold-down ring on top of the filter paper and ensure the filter paper overlaps all sides of the hold-down ring, forming a tight seal.
5. Place filter pan cover onto the filter pan and assembly is complete.

MPF50S SERIES PORTABLE FILTRATION SYSTEMS

CHAPTER 4: OPERATING/FILTERING INSTRUCTIONS

4.1 Filter Operation

WARNING

Use care when draining and filtering oil to avoid the possibility of a serious burn.

1. Sprinkle 8 ounces (1 cup) of filter powder over the filter paper, distributing the powder as evenly as possible. If filtering a second frypot immediately after the first, add only 4 ounces of filter powder for the second filtering.
2. Ensure the power cord is securely plugged into the receptacle on the back of the portable filter. Plug the power cord into a 115V outlet.
3. If solid shortening is filtered through the portable filter, turn the Heater/Filter switch to HEATER (see illustration below). The white indicator light will illuminate. Leave the heater on for 20-30 minutes before operating the filter.

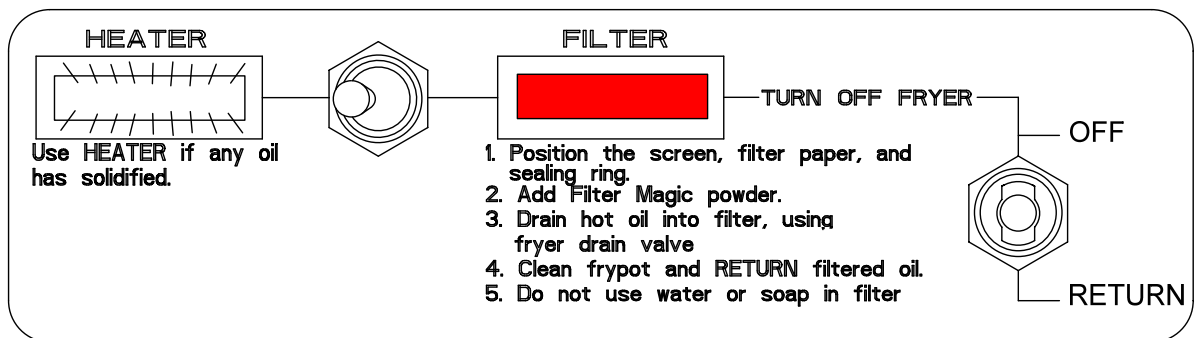

Use the filter heater for 20-30 minutes prior to filtering if solid shortening is filtered.

Note: The filter pump cannot be activated while the switch is in the "Heater" position.

4. Ensure the Off/Return switch is OFF. Turn the Heater/Filter switch to FILTER for filter operation (see illustration below). The red indicator light will illuminate.

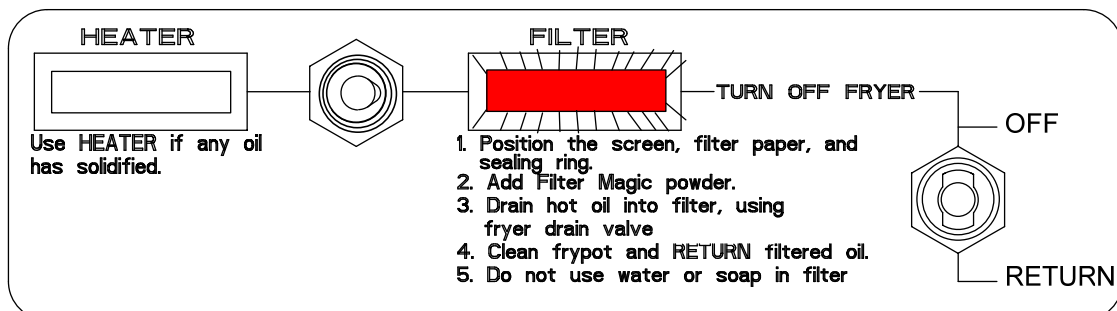

The Heater/Filter switch must be in the FILTER position before the filter pump can be operated. The red light will illuminate when the switch is properly positioned.

MPF50S SERIES PORTABLE FILTRATION SYSTEMS

CHAPTER 4: OPERATING/FILTERING INSTRUCTIONS

4.1 Filter Operation (cont.)

5. Ensure the oil is at operating temperature, 350°F. Turn the fryer off.

⚠ WARNING

The filter pan maximum capacity is 50 lbs. DO NOT OVERFILL THE FILTER PAN.

6. Place filter pan directly under fryer drain valve and drain oil into the filter. Place the filter hose nozzle inside the frypot. Turn the Off/Return to RETURN to start the filter pump (see illustration below).

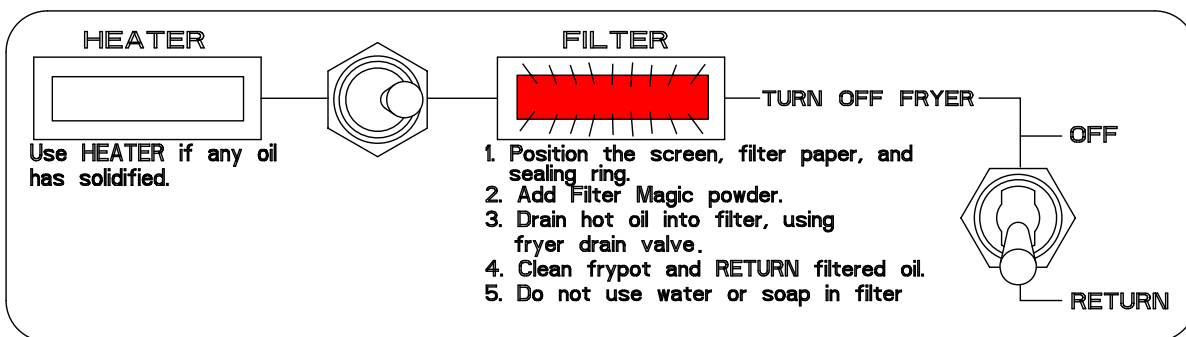

Allow the oil to circulate through the frypot and filter for approximately 5 minutes (process known as "polishing"). Polishing the oil produces maximum filtration and extends the life of the oil. Rinse any residual oil or sediment from the frypot during the polishing process.

Close the drain valve and return the filtered oil to the frypot. Ensure all oil is returned to the frypot before turning filter off.

Allow the portable filter to cool, then remove and discard the filter paper. Clean the interior of the filter pan and all components. Do not use detergent or water in the filter pan for cleaning.

See Chapter 5 for preventative maintenance/cleaning procedures.

MPF50S SERIES PORTABLE FILTRATION SYSTEMS

CHAPTER 5: CLEANING AND MAINTENANCE

5.1 General

Cleaning operations fall into three general categories:

- Wiping unit clean after each filter session;
- Cleaning, changing filter paper and preparing the unit for the next day's business.
- Weekly cleaning to remove oil deposits and other particles.

 **WARNING**

Do not use water jets to clean this equipment. To do so will damage the unit and void the warranty.

 **WARNING**

Never operate the filter unit unless cooking oil is at operating temperature.

5.2 Each Filter Use

Each time the MPF50S portable filter is used:

- Wash down the insides of the filter pan with hot oil during the filtering process. **DO NOT** allow excessive residue buildup to occur inside the filter pan.
- Change filter paper after each filter session or at the end of the day. Scrape excess sediment from filter paper after each frypot is filtered within a filter session. If oil is not returned to the frypot within 7 minutes, the filter paper may be clogged. Change filter paper if this occurs.
- Wipe up any oil which may have splashed or spilled.
- Wipe all exterior surfaces of the filter unit.

 **WARNING**

Do not run water or boil-out solution through the portable filter. Doing so will cause irreparable damage to the pump, and void the warranty.

MPF50S SERIES PORTABLE FILTRATION SYSTEMS
CHAPTER 5: CLEANING AND MAINTENANCE

5.3 Daily— Close Of Business

At the close of a working day, filter the oil in all fryers. When the last fryer is filtered, follow these steps:

1. Ensure the flexible hose and pump lines are clear by running the filter pump for an additional 15–30 seconds after air bubbles start coming from the oil return line. Drain the flexible hose as much as possible, especially if solid shortening is used.
2. Remove the filter pan cover and hold-down ring, and then remove the filter paper and filter paper support screen.
3. Discard filter paper.
4. Wash all filter components with hot soapy water and rinse. DO NOT use soap and/or water inside the filter pan. Wipe residual oil and sediment from inside the filter pan with a clean cloth or paper towel.
5. Rinse all parts with clean water (except filter pan interior), and then dry all filter parts thoroughly before reassembling.
6. Check the hose fitting on the pump and ensure that it is tight. Check plumbing for leaks. See Chapter 6 for service procedures. Check plumbing for leaks.

5.4 Weekly

Follow the same procedure as for "Daily", with these additional steps:

- Clean built-up residue and debris from filter pan by wiping with a clean cloth or paper towel. DO NOT use soap and/or water inside the filter pan. Ensure all components fit properly and function correctly.
- Clean thoroughly under, around, and behind the fryers and filtering area with hot soapy water and rinse.
- Check the hose connection and tighten if hose becomes loose and starts to leak oil.

MPF50S SERIES PORTABLE FILTRATION SYSTEMS

CHAPTER 6: TROUBLESHOOTING/SERVICE PROCEDURES

6.1 Operating Problems

Plugged lines and plugged filter paper account for over 90 percent of filtration system malfunctions. A general troubleshooting chart, included in this chapter, provides instructions in diagnosing common malfunctions. Contact a factory-authorized service technician for troubleshooting beyond the scope of the operator.

A. Plugged Lines

1. To guard against plugged lines when using solid shortening, follow these guidelines:
 - a. Turn the Heater/Filter switch to HEATER and allow the heater to remain on for 20-30 minutes before attempting a filter cycle.
 - b. At the end of the filtering cycle, let the filter bubble into the fryer through the flexible hose for about 15-30 seconds. If it is blowing bubbles, air is moving through the lines and the filter is less likely to be plugged.
 - c. When filtering is complete, drain oil or shortening from the hose.

B. Plugged Paper

Improper use of the filter powder will cause a slow oil flow return rate. The first indication of paper plugging is a surging, jerking movement of the hose. To correct this, review the instructions for the correct use of filter powder, and change the filter paper more frequently. When filtering several fryers prior to changing paper, ensure that excess sediment is scraped off the filter paper after filtering each frypot.

6.2 General Troubleshooting

The following chart contains information to assist in diagnosing the most common malfunctions with portable filtration systems. Possible solutions and/or corrective actions are given for each scenario.

If the malfunction cannot be diagnosed using the information in this section, contact your Factory Authorized Service Agent for repairs.



Use extreme care when testing electrical circuits. Live circuits will be exposed.



Inspection, testing and repair of gas or electrical equipment should be performed by qualified personnel.

MPF50S SERIES PORTABLE FILTRATION SYSTEMS
CHAPTER 6: TROUBLESHOOTING/SERVICE PROCEDURES

6.2 General Troubleshooting (cont.)

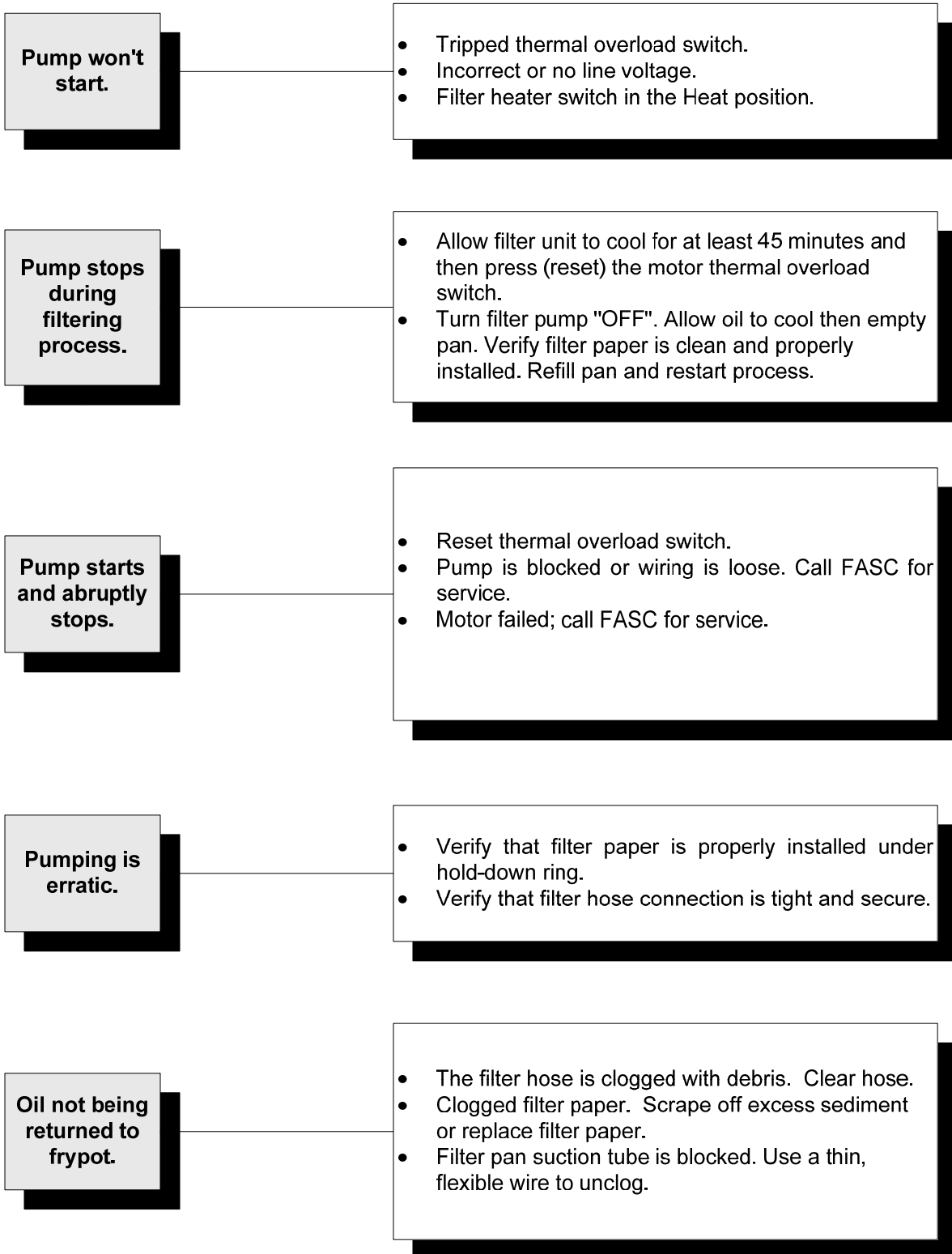

**MPF50S SERIES PORTABLE FILTRATION SYSTEMS
CHAPTER 6: TROUBLESHOOTING/SERVICE PROCEDURES**

6.3 Wiring Diagrams

6.3.1 MPF50SS 115

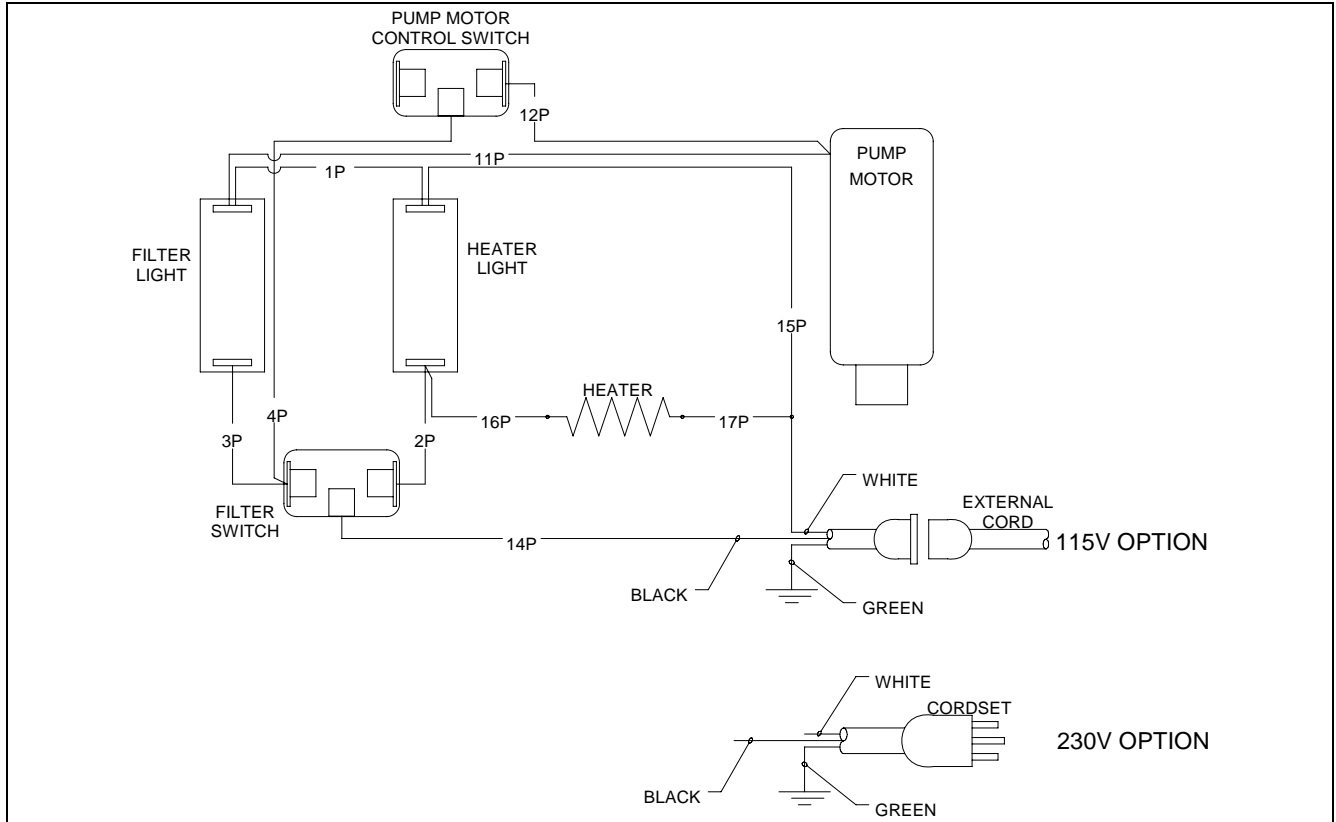

6.3.2 MPF50S/MPF50SS 115/230V Pump Motor Wiring

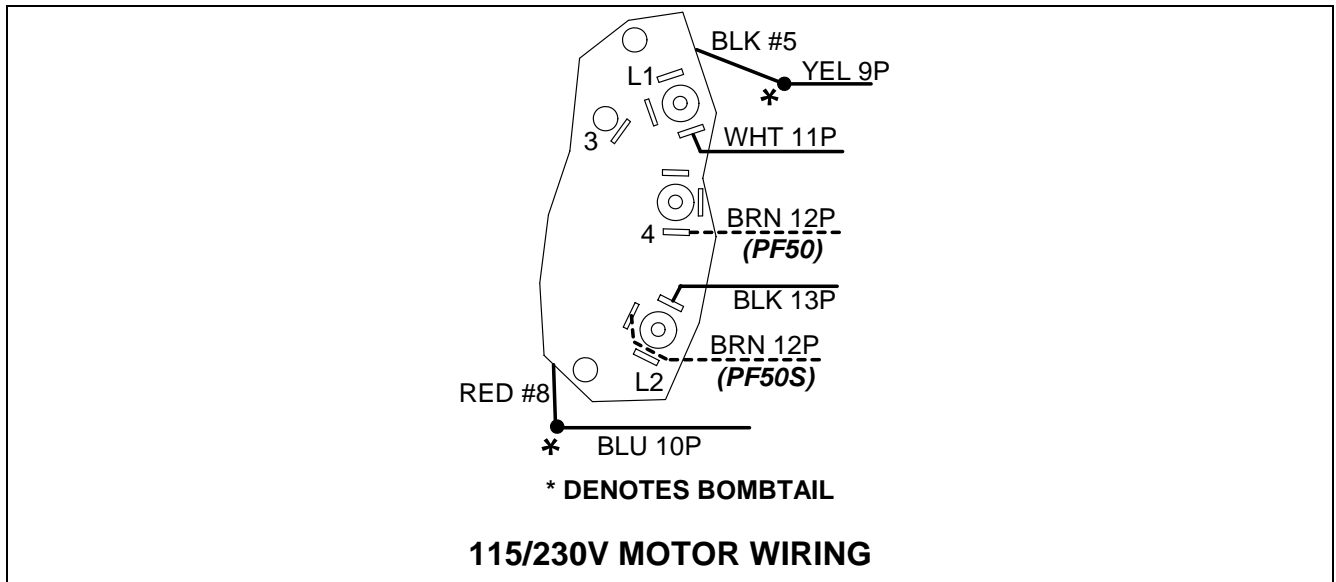

MPF50S SERIES PORTABLE FILTRATION SYSTEMS
CHAPTER 6: TROUBLESHOOTING/SERVICE PROCEDURES

6.4 Service Procedures

6.4.1 Replace Lights/Switches

⚠ WARNING

Disconnect power cord from electrical power before servicing.

1. Disconnect power cord from power supply.
2. Remove four screws securing the switch panel to the control panel.
3. Lift the panel out of the control panel to access wiring.

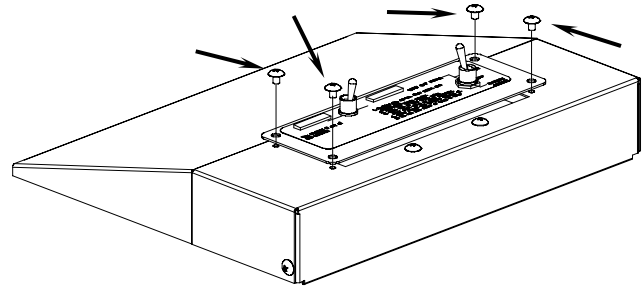

Remove screws (arrows) securing switch panel to the control panel.

4. Mark the wire locations on the defective switch/light and disconnect the wiring.
5. Install new switch or light, connect the wiring and install the switch panel. Replace the screws removed in Step 1.

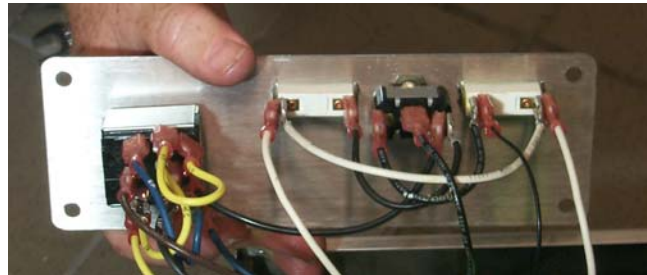

Mark wiring locations on defective switch/light before disconnecting wires.

MPF50S SERIES PORTABLE FILTRATION SYSTEMS

CHAPTER 6: TROUBLESHOOTING/SERVICE PROCEDURES

6.4.2 Replace Heater Strip

1. Disconnect power cord from power supply.
2. Perform Step 2, Section 6.4.3.1, Replace Motor.
3. Remove screws securing outer panels and cord-holding bracket. Remove bracket and the panels.



Remove screws securing outer panels.

4. Turn the unit on its side and remove four nuts securing the filter pan to the base assembly. Carefully pull the filter pan away from the base to gain access to heater strip. Use care not to damage the flexlines connecting the pan to the pump.

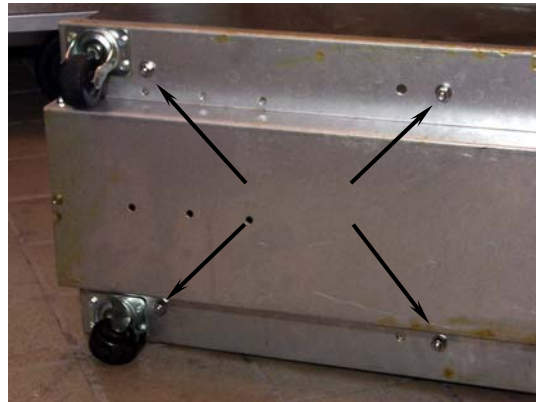

Remove four nuts securing filter pan to base (arrows).

5. Remove foil-insulating tape securing the heater strip to the pickup tube. Remove the heater strip from the pickup tube.
6. Remove the remainder of the foil-insulating tape from the flexline(s) and the pump, and then remove the heater strip. Note routing of the heater strip on the pump and flexline(s) prior to heater strip removal.



Remove foil-insulating tape to expose heater strip (arrow).

MPF50S SERIES PORTABLE FILTRATION SYSTEMS

CHAPTER 6: TROUBLESHOOTING/SERVICE PROCEDURES

6.4.2 Replace Heater Strip (cont.)

7. 115VAC Filters: Disconnect the black wire from the heater indicator light on the switch panel (left, black arrow), and the white wire from the receptacle (white, white arrow).

230VAC Filters: Disconnect the red wire connected to the power supply cord (bombtail connection) and the violet wire connected to the Heater Indicator light on the switch panel.

8. Starting at the sump on the pan bottom, install the new heater strip, using foil tape to secure the heater to the pickup tube (see Step 3, this section).
9. Route the heater strip over the plumbing and around the pump as previously removed in Step 4.
10. Complete installation by securing strip with foil tape. Reconnect the wire connections disconnected in Step 7, this section. Reassemble filter by reversing Steps 1-3, this section.

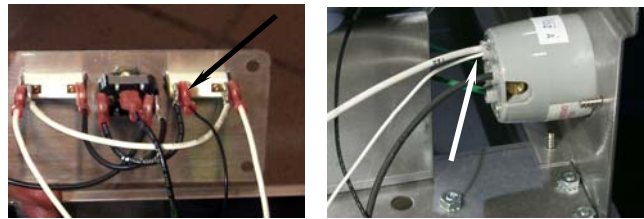

Heater strip wiring connections at switch panel and receptacle (115V heater strip shown).

MPF50S SERIES PORTABLE FILTRATION SYSTEMS

CHAPTER 6: TROUBLESHOOTING/SERVICE PROCEDURES

6.4.3 Replace Motor/Pump

1. Disconnect power cord from power supply.
2. Perform Step 2, Section 6.4.1. Remove two screws securing the handle brackets to the control panel (arrows). Do not remove the remaining handle-bracket screws. Remove remaining screws securing control panel to filter base. Lift the control panel from the base and work the switch panel through the control panel opening. Leave the switch panel wired and set aside, using care not to stretch and disconnect wiring. Remove control panel.

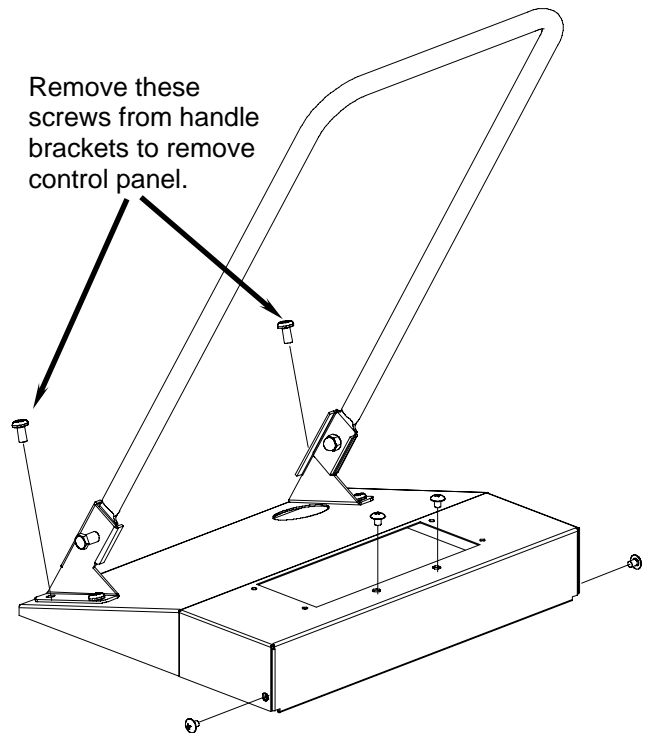

Remove screws illustrated to remove control panel. (Switch panel omitted for clarity.)

3. Remove cord-holder bracket and outer panels (see Step 3, Section 6.4.2 for reference).

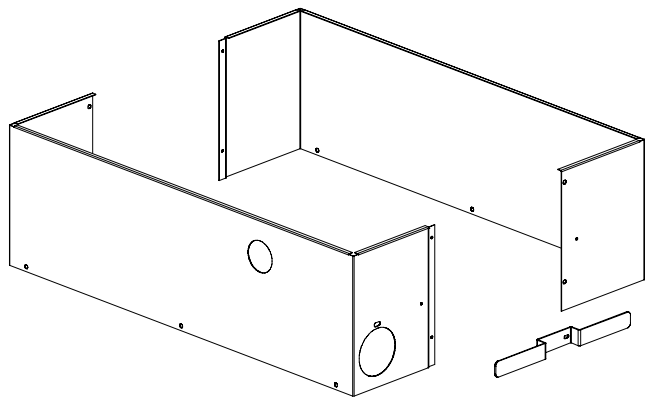

Remove cord-holder bracket and outer panels.

MPF50S SERIES PORTABLE FILTRATION SYSTEMS

CHAPTER 6: TROUBLESHOOTING/SERVICE PROCEDURES

6.4.3.1 Replace Motor

4. Remove four bolts securing the pump to the motor. Leave the plumbing connected to the pump. Use care not to damage the flex supply lines connected to the pump. Remove the pump gasket for reassembly.

5. Remove six screws securing the motor bracket from the bottom of the base. Support the motor with one hand when removing the screws. Pull the motor/motor-bracket out of the cabinet and set on floor. Use care not to damage the motor wiring. Remove four bolts securing the motor to the motor-bracket. Place the replacement motor next to the old motor for ease of rewiring.

6. Remove the cover plate to access the motor wiring. Splices or bombtails are needed for two connections. Rewire the replacement motor using the wiring diagram in Section 6.3.4.

7. Complete installation of replacement motor by reversing the above steps.

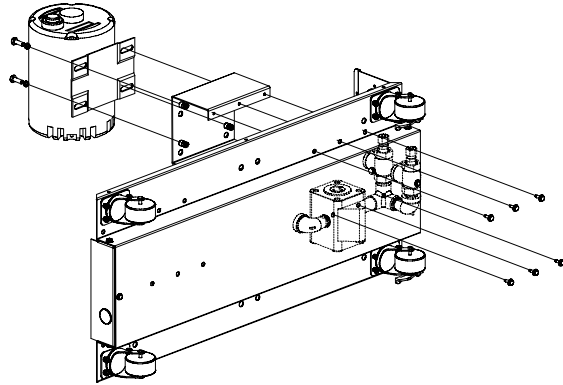

Remove six screws from the base bottom to remove the motor and motor bracket. Remove four bolts securing the motor to motor-bracket after removing the bracket from the base.

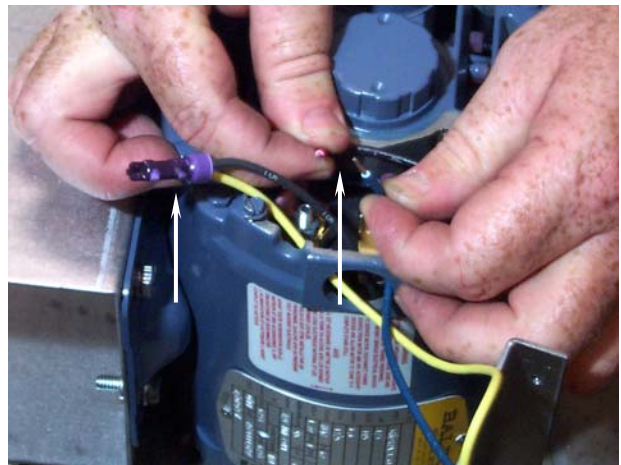

Two connections require splices or bombtails (arrows).

MPF50S SERIES PORTABLE FILTRATION SYSTEMS CHAPTER 6: TROUBLESHOOTING/SERVICE PROCEDURES

6.4.3.2 Replace Pump

1. Disconnect power cord from power supply.
2. Perform Steps 2 and 3, Section 6.4.3.1, Replace Motor.
3. Remove foil insulation tape and heater strip from pump and flex lines. Remove the heater strip from the pump and disconnect flexlines from the check valve connections.
4. Remove pipefittings from pump before removing pump from motor.
5. Remove four bolts securing the pump to the motor. Remove the pump and pump gasket. Fit new pump gasket and install new pump on motor. Torque pump bolts to 15-foot pounds. Do not over-tighten the bolts.
6. Reinstall all removed components during pump removal by reversing the above steps.



Remove foil insulation tape covering the heater strip and remove heater strip from the pump and flexlines.

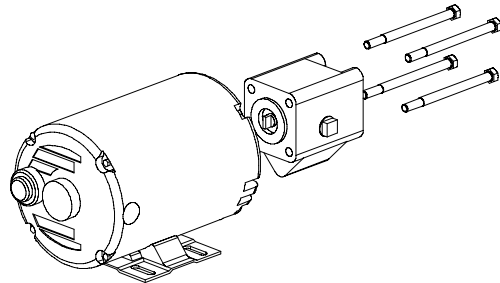

Remove four bolts securing the pump to the motor. Remove pump and gasket from motor.

MPF50S SERIES PORTABLE FILTRATION SYSTEMS

CHAPTER 6: TROUBLESHOOTING/SERVICE PROCEDURES

6.4.3.3 Replace Wand Hose

1. Disconnect power cord from power supply.
2. Remove cord-holder bracket and outer panels (see Step 3, Section 6.4.2 for reference).
3. Unscrew the hose fitting with an open-end wrench from the elbow on the pump.
4. Install the new hose, using care not to cross-thread the connections. Use an approved pipe sealant on the threads to ensure a leak-proof connection. **DO NOT OVER-TIGHTEN THE CONNECTION.**
5. Replace the outer panels and the cord-holder bracket.

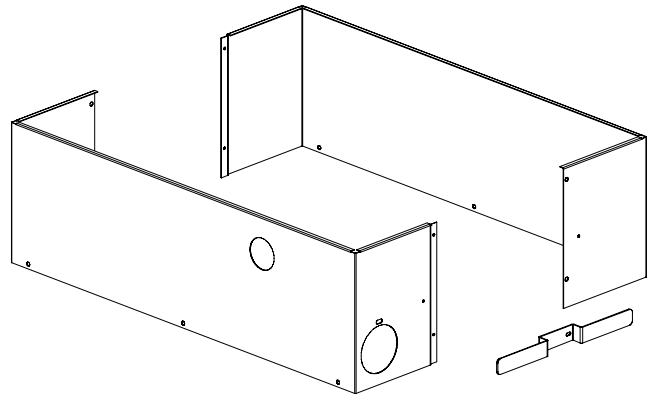

Remove cord-holder bracket and outer panels.



Remove hose fitting (arrow) with an open-end wrench. Use pipe sealant when installing new hose.

MPF50S SERIES PORTABLE FILTRATION SYSTEMS

CHAPTER 7: PARTS LIST

7.1 MPF50S Parts List

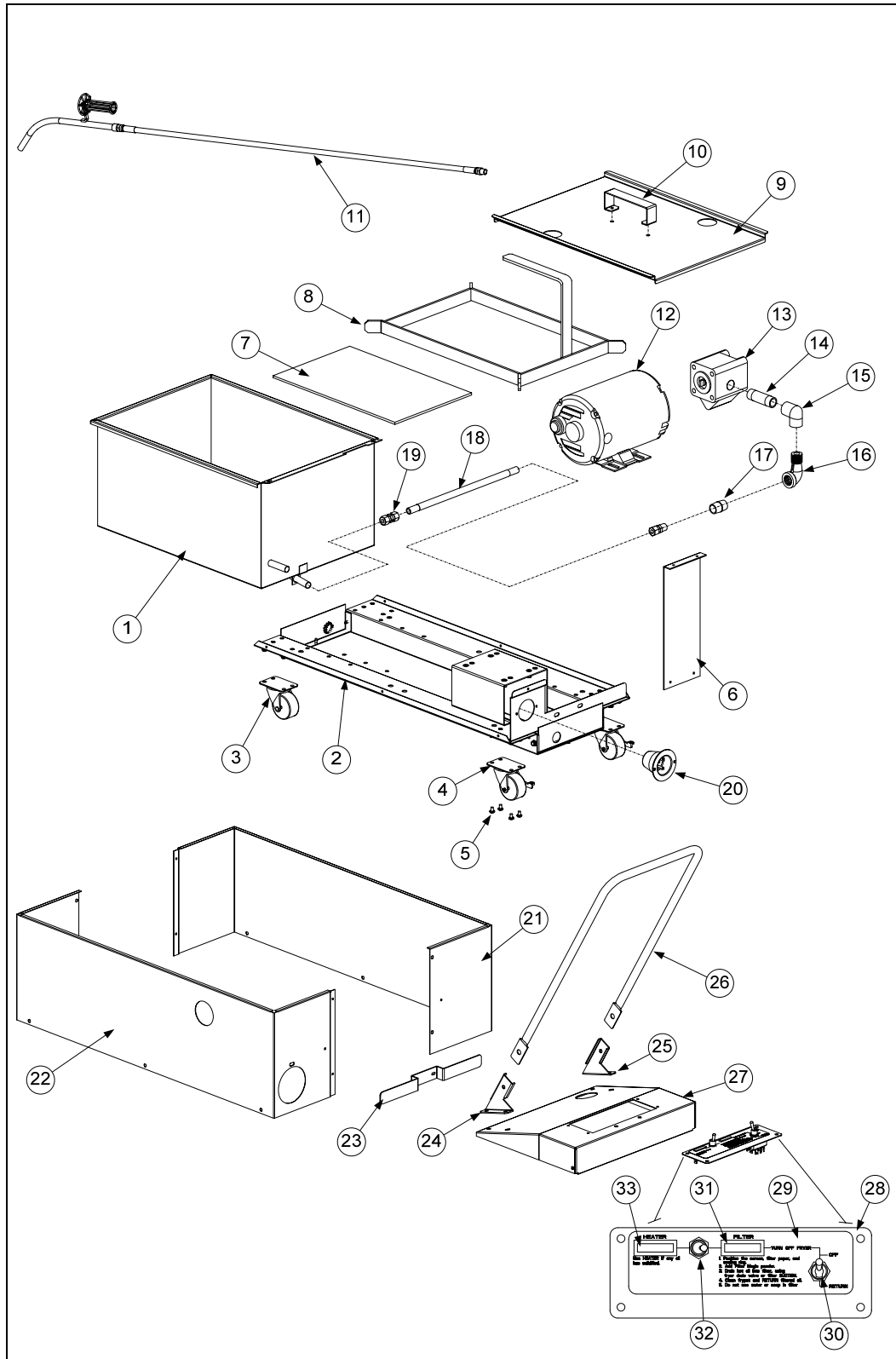

MPF50S SERIES PORTABLE FILTRATION SYSTEMS
CHAPTER 7: PARTS LIST

Item	Part #	Description
1	823-6231	Pan, Filter
2	806-5223SP	Base Assembly (Includes items 3 & 4)
	900-9542	Bracket, Motor-Mount – All MPF50S
	900-1748	Brace, End- Filter Base
	900-8585	Brace, Rear Cross- Filter Base
3	810-2805	Caster, 2"- Swivel (Without Brake)
4	810-2806	Caster, 2"- Swivel (With Brake)
5	809-0475	Screw- 10-32 x 5/16 Hex
6	900-3751	Bracket, Standoff
7	900-8825	Screen, Filter Paper Support
*	803-0003	Paper, Filter 17 ¾" x 12 ½" 100 sheets
*	803-0002	Powder, Filter, 80 packets
8	823-0889	Ring, Hold-down
9	230-2836	Lid, Filter Pan
10	810-3162	Handle, Pan Lid 802-
*	826-1379	Screw, #10 x ½" Phillips (Lid Handle) (Qty. of 10)
*	809-0184	Washer, Lock - #10 (Lid Handle)
*	809-0020	Nut, Cap- 10-24 (Lid Handle)
11	106-7847	Complete Hose/wand assembly
*	810-3303	Hose
12		Motor, Filter Pump
	826-1712	115V 60HZ 1/3 HP (Includes Motor and Gasket)
	826-1270	230/240V 50/60HZ 1/3 HP (Includes Motor and Gasket)
13	826-1264	Pump, Filter - 4GPM (Includes Pump and Gasket)
14	813-0265	Nipple, ½ x 2-½" NPT BM
15	813-0062	Elbow, ½" NPT BM
*	806-3844	Heater Strip, 120V 40W
*	806-7435	Heater Strip, 230/240V 70W
16	813-0165	Elbow, Street- ½" NPT BM
17	813-0022	Nipple, ½" x Close NPT BM
18	810-1435	Flexline, ½ x 12" S/S Hose
19	813-0545	Union, ½ x ½" Flexline Hose
20	807-1219	Receptacle, 115V 3-Wire (120V Domestic Units Only)
*	807-1224	Cord, Power - 3-Wire 115V
*	807-4317	Cord, Power – Euro 3-Wire 230/240V
21	910-8587	Panel, Outer - Left Side
22	910-8586	Panel, Outer - Right Side
23	910-3788	Holder, Power Cord

**MPF50S SERIES PORTABLE FILTRATION SYSTEMS
CHAPTER 7: PARTS LIST**

24	912-2616	Bracket, Handle- Right
25	911-2616	Bracket, Handle- Left
*	826-1380	Screw, ¼-20 x ½" Slotted Head (For Handle Bracket) (Qty. of 5)
26	910-9169	Handle, Portable Filter
*	826-1389	Bolt, ¼-20 x ¾" Hex Head (Qty. of 10)
*	810-0219	Spacer, Handle Bolt
*	809-0047	Nut, Cap- ¼-20 High Profile S/S
27	824-0403	Panel, Control
28	910-0982	Panel, Switch
29	802-1438	Label, Switch Plate
30	807-1041	Switch, Toggle, Off-Return
31	807-1060	Light, Indicator- Red Lens (Filter Indicator Light) 120V
	807-1086	Light, Indicator- White Lens (Filter Indicator Light) 230/240V (Europe Only)
32	807-1041	Switch, Toggle- 2-Way SPDT - All PF50
33	807-1061	Light, Indicator- White Lens (Heater Indicator Light) 120V
	807-1086	Light, Indicator- White Lens (Heater Indicator Light) 230/240V (Europe Only)
* Not Illustrated		



Enodis®
One Company, Countless Solutions

Frymaster, L.L.C., 8700 Line Avenue, PO Box 51000, Shreveport, Louisiana 71135-1000
Shipping Address: 8700 Line Avenue, Shreveport, Louisiana 71106

TEL 1-318-865-1711 FAX (Parts) 1-318-219-7140 FAX (Tech Support) 1-318-219-7135